

TIPO TYPE		POTENZA NOMINALE NOMINAL POWER		POTENZA ASSORBITA INPUT POWER	AMPERE		Q = PORTATA - CAPACITY												
Monofase Single-phase	Trifase Three-phase	P2		P1	Monofase Single-phase	Trifase Three-phase	Prevalenza manometrica totale in m.C.A. - Total head in meters w.c.												
		HP	kW	kW			m³/h	0,6	1,2	1,8	2,7	3,6	4,8	5,4	6	7,2	9	9,6	12
CAM 152	CA 152	1,5	1,1	1,5	7	3	45	42	40	35	33	28	25	22	16	10			
CAM 202	CA 202	2	1,5	2	9	4,2	47	46	43	39	35	32	29	27	20	13			
CAM 302	CA 302	3	2,2	3	13,5	5,2	55	53	52	50	48	45	43	42	38	33	32	25	22

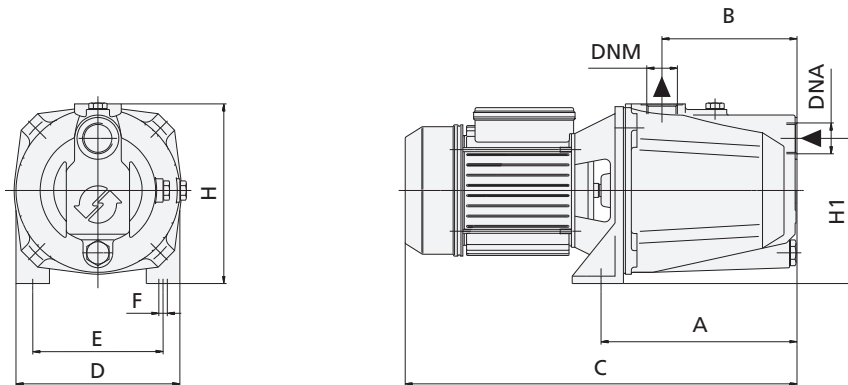

TIPO TYPE		DIMENSIONI mm - DIMENSIONS mm										DIMENSIONI DIMENSIONS mm			PESO WEIGHT
Monofase Single-phase	Trifase Three-phase	A	B	C	D	E	F	H	H1	DNA	DNM	P	L	H	Kg
CAM 152	CA 152	284	153	505	206	145	12	217	170	1" ¼	1"	234	550	285	27,6
CAM 202	CA 202	284	153	505	206	145	12	217	170	1" ¼	1"	234	550	285	27,6
CAM 302	CA 302	290	174	570	225	166	12	230	183	1" ½	1" ¼	245	600	300	31,5

APPLICAZIONI

Elettropompe autoadescenti bigiranti con eiettore, indicate per aspirazioni fino a 9 mt.

Smontando l'eiettore dal corpo pompa e collegandolo alla pompa tramite una doppia tubazione più una valvola di fondo permette un'aspirazione fino a 35 mt. in profondità.

Adatte per usi civili e industriali, per il sollevamento di acqua pulita, di acqua miscelata a gas e liquidi chimicamente non aggressivi per i particolari della pompa.

APPLICATION

Selfpriming twin-impeller water pumps with ejector for suction up to 9 mt. A suction up to 35 mt. depth can be allowed by taking the ejector down and connecting it to the pump by means of a double hose and a foot valve.

Suitable for civil and industrial purposes and to drain clean, gas mixed water and non-aggressive liquids.

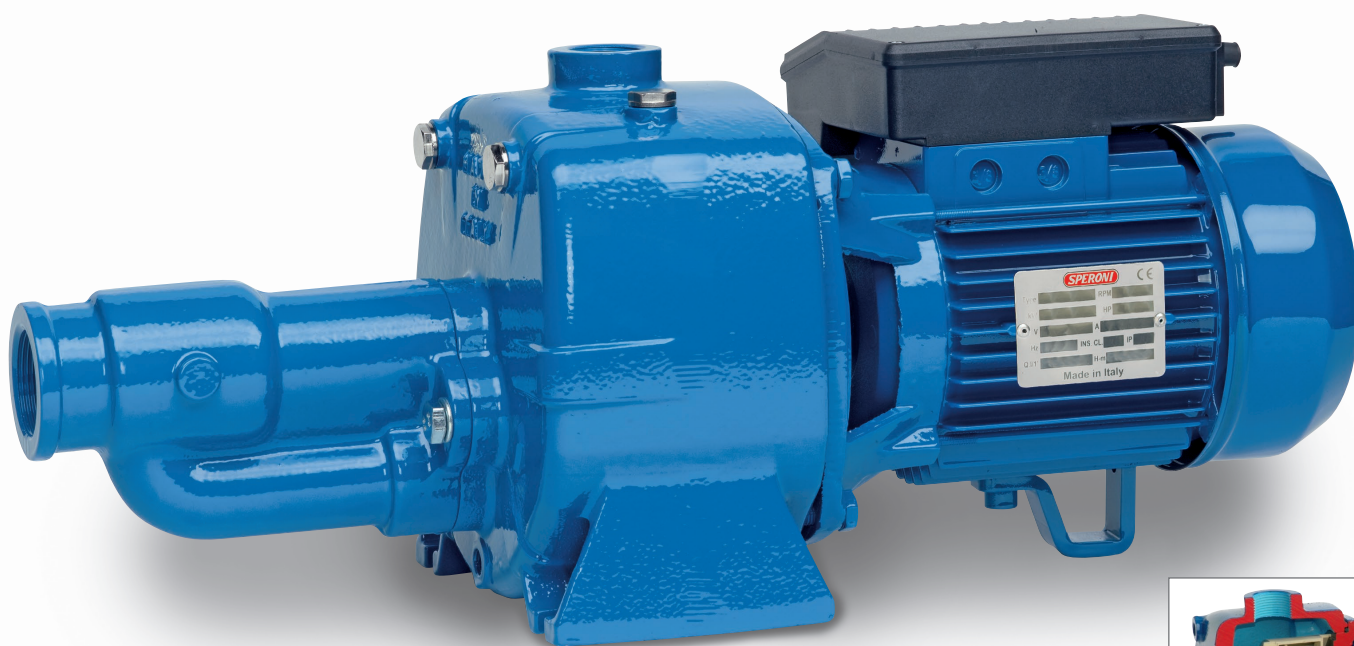

LIMITI D'IMPIEGO

- Temperatura liquido fino a 35°C (per un uso domestico secondo EN 60335-2-41)
Temperatura max. liquido: 35°C (per altri impieghi)
- Temperatura ambiente fino a 40° C
- Altezza d'aspirazione manometrica fino a 9 mt.
- Servizio continuo

MOTORE

- Monofase 230V-50Hz
- Trifase 230/400V-50Hz
- Motore elettrico ad induzione a 2 poli (n = 2850 min⁻¹)
- Isolamento Classe F
- Protezione IP 55

MATERIALI

- | | |
|---------------------|-----------------------|
| - Corpo pompa | Ghisa |
| - Supporto motore | Ghisa |
| - Giranti | Noryl |
| - Diffusore | Noryl |
| - Eiettore | Ghisa |
| - Albero motore | Acciaio Inox AISI 304 |
| - Tenute meccaniche | Ceramica/Grafite/NBR |

OPERATING CONDITIONS

- Liquid temperature up to 35°C (for home use according to EN 60335-2-41)
Max. liquid temperature: 35°C (for other uses)
- Ambient temperature up to 40°C
- Total suction lift up to 9 mt.
- Continuous duty

MOTOR

- Single-phase 230V-50Hz
- Three-phase 230/400V-50Hz
- Two-Pole induction motor (n = 2850 min⁻¹)
- Insulation Class F
- Protection IP 55

MATERIALS

- | | |
|--------------------|--------------------------|
| - Pump body | Cast Iron |
| - Motor Support | Cast Iron |
| - Impellers | Noryl |
| - Diffuser | Noryl |
| - Ejector | Cast Iron |
| - Shaft with rotor | Stainless Steel AISI 304 |
| - Mechanical seal | Ceramic/Graphite/NBR |

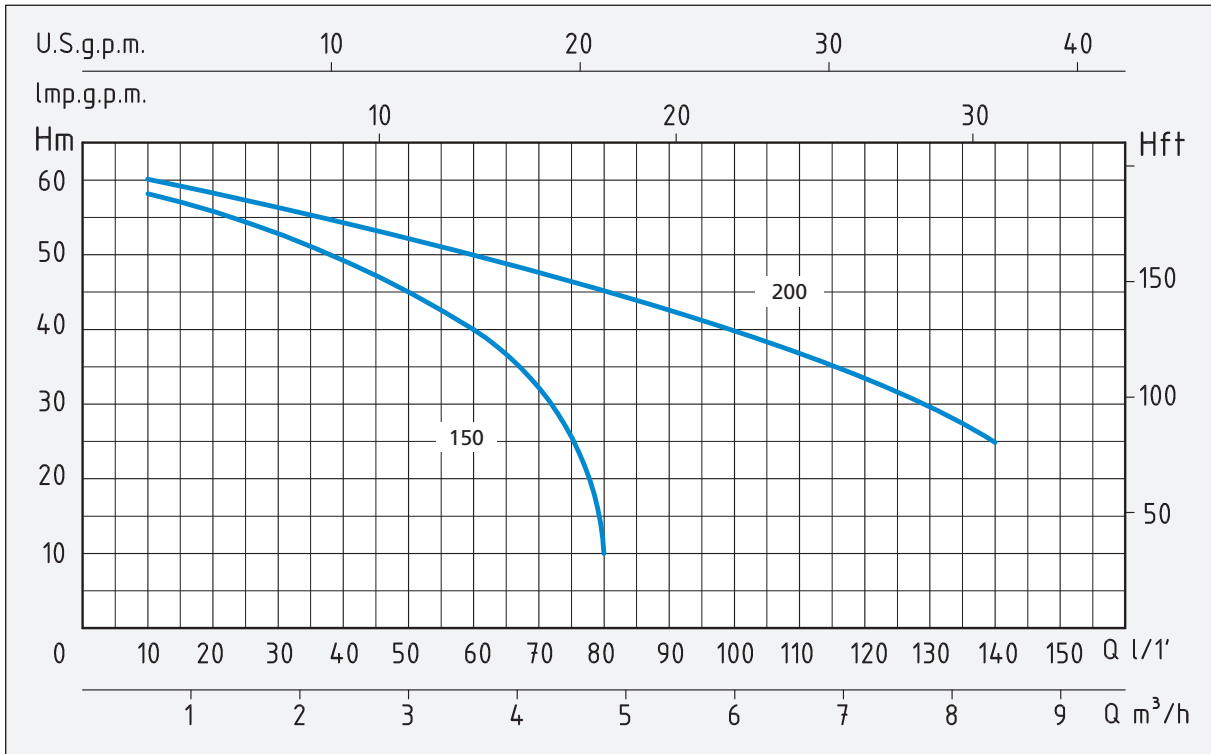

TIPO TYPE		POTENZA NOMINALE NOMINAL POWER		POTENZA ASSORBITA INPUT POWER	AMPERE		Q = PORTATA - CAPACITY												
Monofase Single-phase	Trifase Three-phase	P2		P1	Monofase Single-phase	Trifase Three-phase	m³/h	0,6	1,2	1,8	2,4	3	3,6	4,2	4,8	5,4	6	7,2	8,4
		HP	kW	kW			lt/1'	10	20	30	40	50	60	70	80	90	100	120	140
Prevalenza manometrica totale in m.C.A. - Total head in meters w.c.																			
CAM 150	CA 150	1,5	1,1	1,5	7	3	H	58	55	52	49	45	40	30	10				
CAM 200	CA 200	2	1,5	2,5	12	5	(m)	60	58	57	55	52	50	47	45	42	39	33	25

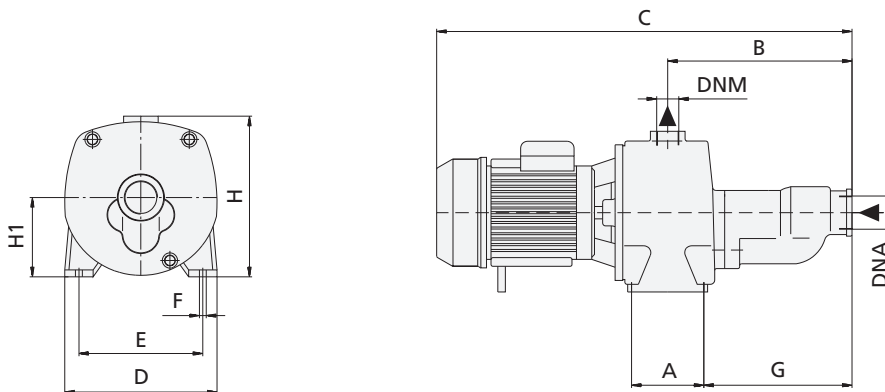

TIPO TYPE		DIMENSIONI mm - DIMENSIONS mm											DIMENSIONI DIMENSIONS mm			PESO WEIGHT	
Monofase Single-phase	Trifase Three-phase	A	B	C	D	E	F	G	H	H1	GIRANTI IMPELLERS	DNA	DNM	P	L	H	Kg
CAM 150	CA 150	104	265	605	220	172	10	212	240	115	2	1" 1/2	1"	234	606	280	29,8
CAM 200	CA 200	104	265	605	220	172	10	212	240	115	2	1" 1/2	1"	234	606	280	30,8